

SONIC ELECT SAIL DRIVES Mk II

THROUGH HULL SAILDRIVES

AUXILIARY PROPULSION FOR SAILING VESSELS

20 to 33 ft/6 to 10 mtrs.

2 Models available:

Direct Drive 1:1

Reduction Drive 2:1

For use with L.E.M.C.O. 24V or 36V high torque permanent magnet DC motor/controller and operating lever or similar motor systems.

Bronze or Aluminium lower unit available. Choice of 2 or 3 blade fixed propeller or folding.

Motor and Sonic UK manufacture.

- Simple to install
 - Cheaper to fit
 - Quiet to run
 - No diesel smell
 - No wet exhaust
 - No water intake
 - No diaphragm
 - No GRP base.
- etc etc.

But always remember
SONIC ELECT SAILDRIVE
is quiet, smooth and
gives pollution free
running.

**THE NEXT BEST THING
TO SAILING**

Sillette-Sonic Ltd
182 Church Hill Road
North Cheam, Sutton
Surrey SM3 8NF
United Kingdom

tel: +44 (0)20 8715 0100
fax: +44 (0)20 8288 0742
mobile: +44 (0)77 1027 0107
e-mail: sales@sillette.co.uk
website: <http://www.sillette.co.uk>

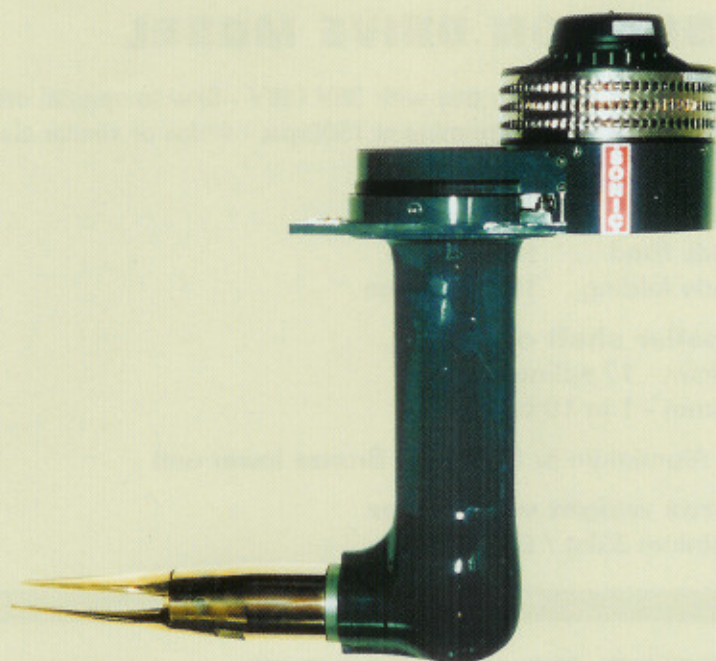

REDUCTION DRIVE MODEL

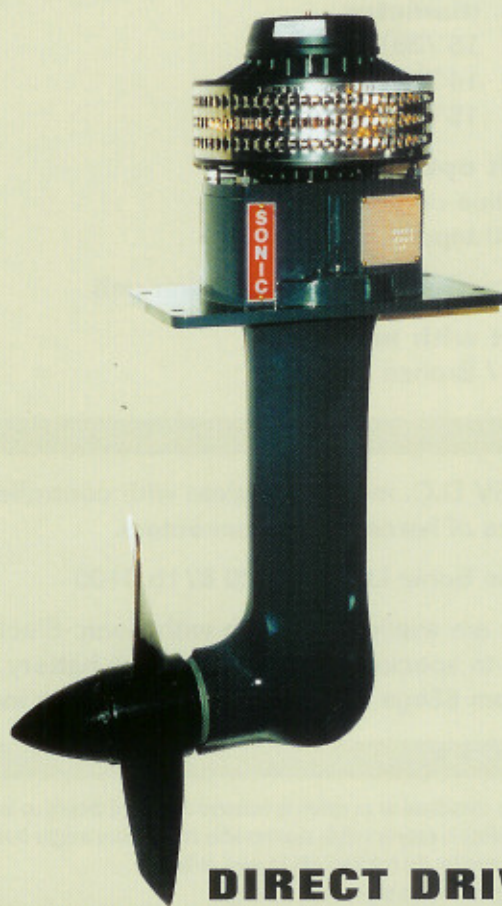

DIRECT DRIVE MODEL

a member of the

British Marine
Federation

SONIC ELECT SAIL DRIVES

Mk II

TECHNICAL DETAILS

REDUCTION DRIVE MODEL

2:1 Reduction. For use with 36V (48V - 8kw to special order).
L.E.M.C.O. D.C. motor running at 1500rpm - 4½kw or similar electric motors.

Propeller max. diameter

- 2 blade fixed 17"/432mm
- 3 blade fixed 16"/406mm
- 2 blade folding 16½"/419mm

Propeller shaft options

- Ø 28mm - 17 spline or
- Ø 25mm - 1 in 10 taper

LM6 Aluminium or Gunmetal Bronze lower unit

Approx weight with motor

Aluminium 33kg / Bronze 40kg

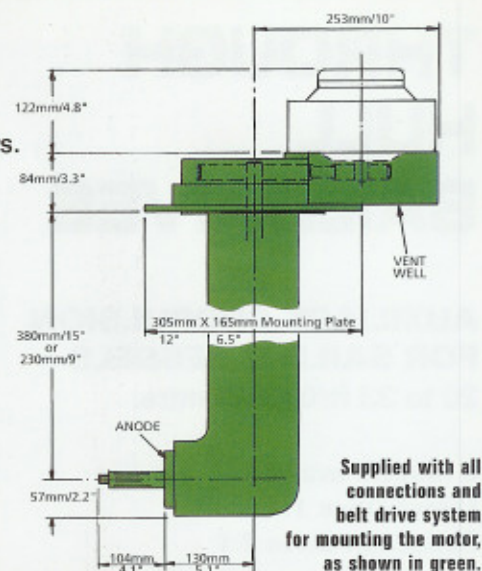

TECHNICAL DETAILS

DIRECT DRIVE MODEL

1:1 Direct Drive. For use with 24V L.E.M.C.O. D.C. motor running at 1000rpm/2.8kw or similar electric motors.

Propeller max. diameter

- 2 blade fixed 15"/381mm
- 3 blade fixed 14"/356mm
- 2 blade folding 15"/381mm

Propeller shaft options

- Ø 28mm - 17 spline or
- Ø 25mm - 1 in 10 taper

LM6 Aluminium or Gunmetal Bronze lower unit

Approx weight with motor

Aluminium 28kg / Bronze 35kg

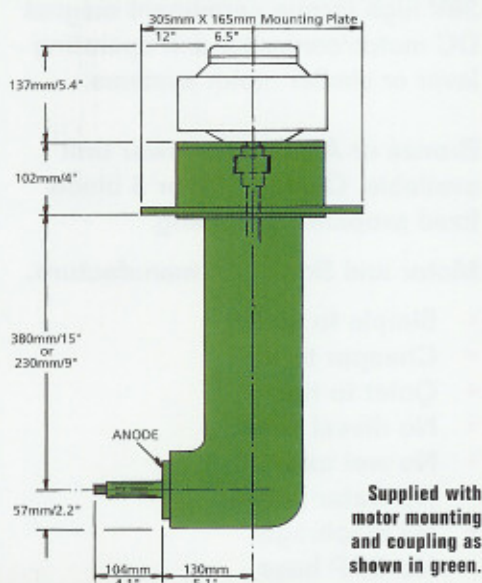

L.E.M.C.O. 24V or 36V D.C. motor complete with controller and operating lever. 6 mtrs of harness and connectors.

Available from: Sillette Sonic Ltd Tel. 020 8715 0100

Other motor systems are available for use with Sonic-Elect including use of a 48V system to special order. Also various battery packs & chargers. Weights from 65kgs and other control options available.

The Sonic Elect Saildrive should be considered as an option to outboard or inboard diesels up to say 16HP for auxiliary propulsion. The package which is easy to install, requires little maintenance weighs less than 120kg including basic battery pack and remember the batteries can be used as ballast.

A 100Ah/24V battery pack allows up to 3 hours of peaceful cruising.

The addition of 2 extra batteries, weight 60 kg can double this range. With a potential re-charge cost of under 20p/30cents and minimal servicing, the electric saildrive is a cost effective option, which offers quiet pollution free cruising without the vibration associated with a diesel engine. Batteries can be re-charged at the marina, or by wind generator, solar panel, or consider a portable generator set for emergencies.

Due to continual development Sillette Sonic Ltd reserve the right to alter, modify or replace any specification or design feature without prior notice please check when ordering.

CUT OUT AND MOUNTING DETAIL BOTH MODELS

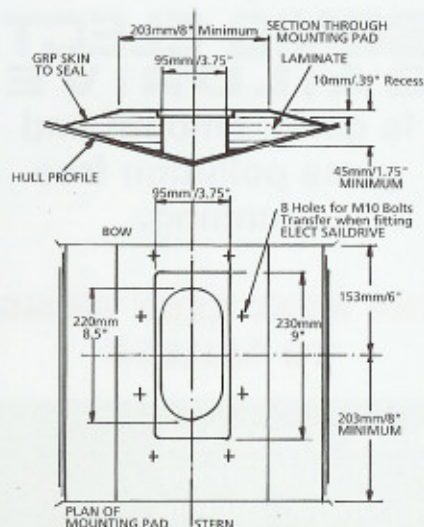

Bell

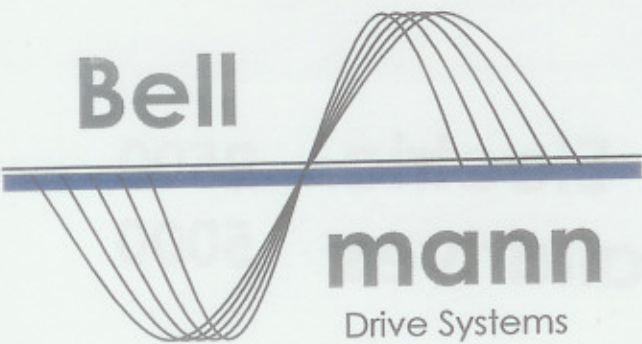

mann
Drive Systems

**Sonic Electric
Saildrives**

**2500
5000**

Sonic and Aquapella The Power of Silence





Sonic Electric Saildrives

2500
5000

- Compact sail drive
- Very Quiet
- Easy Installation
- No Maintenance
- Complete System



The very well known Sonic sail drive is equipped with an Aquapella electric drive system to create a very quiet and complete drive package. The system comprises of:

- Saildrive
- PMG 132 Electric motor
- Electronic speed controller CPM 100
- Joystick
- Display for voltage, current, Ah used, and messages



	Sonic 2500	Sonic 5000
Power output	2,4 kW continuous	4,8 kW continuous
Speed propeller shaft	1120 RPM	1120 RPM
Voltage	24V (nominal)	48 V (nominal)
Energy efficiency	Appr. 82% for the complete system	

Aquapella

Is produced by:

Bellmann B.V.
 Witte Paal 104
 1742 NW Schagen
 Netherlands
 Tel. +31 (0) 224-217180
 Fax. +31 (0) 224-217190
www.bellmann.nl

Sillette-Sonic Ltd

Unit 2, Beverley Trading Estate, 190-192 Garth Rd,
 Morden, Surrey, SM4 4LU, UK
 email: sales@sillette.co.uk
 website: www.sillette.co.uk
 Tel: 020 8337 7543
 Fax: 020 8330 9014

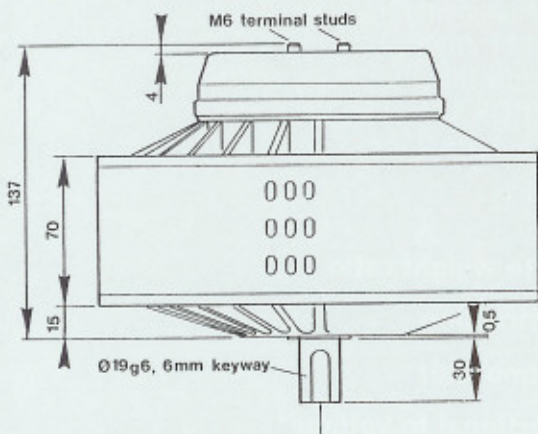
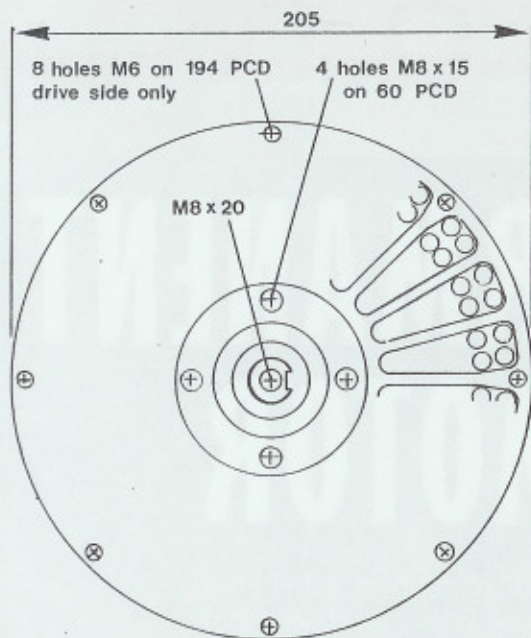

PERFORMANCE CURVES

Curves are available for all voltages. Please contact your local distributor for further details.

CURRENT RATING

Nominal 200 amps at the maximum rated voltage.

SPEED RANGE

All motors are rated 60 rpm per volt, maximum speed limit is 4000. Applications requiring low maintenance and long-term reliability should not exceed 48V nominal.

PATENTS

European 0230759; USA 4823039; Japan 61-304083 (pending); others pending.

For further information and sales details please contact:

Manufacturing

Lemco Ltd., Unit 8, Heath Close, Heathpark Ind. Est., Honiton, Devon, England EX14 8SE.

Tel: +44 (0) 1404 44132

Fax: +44 (0) 1404 47050

Registered in England 3288517

Distributors

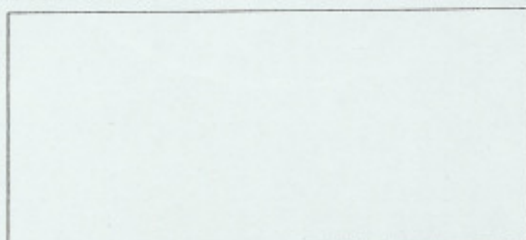

Part of the Asmo Group

24 VOLTS

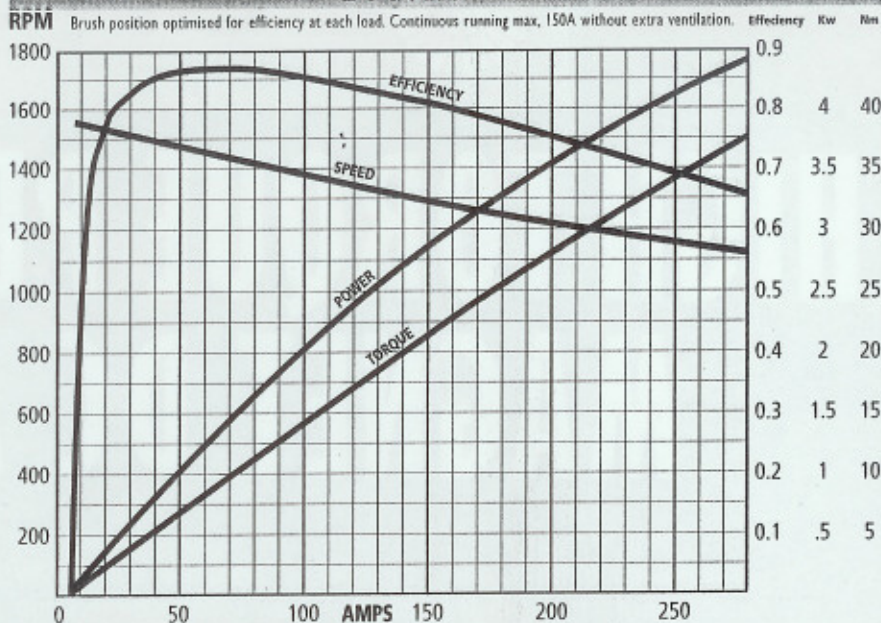

36 VOLTS

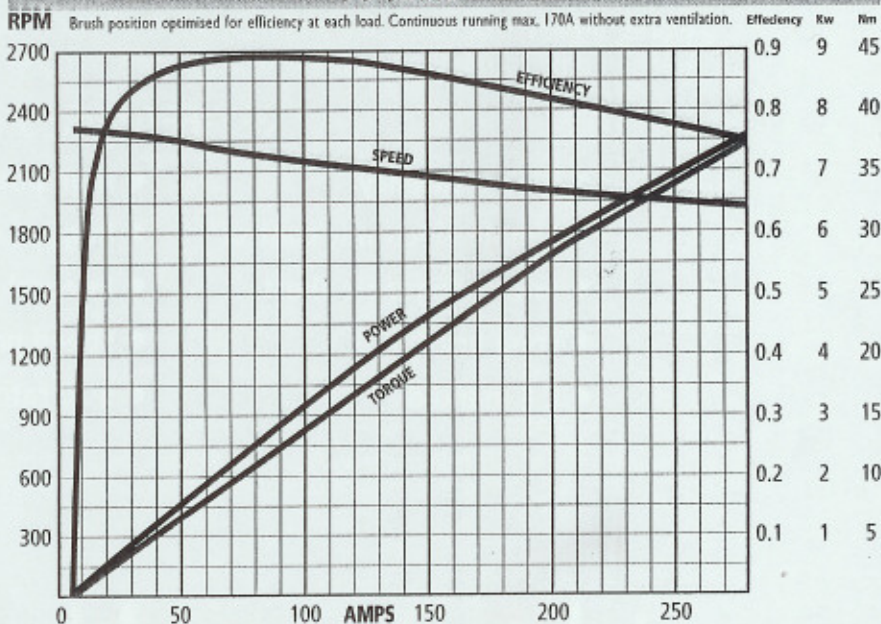

48 VOLTS

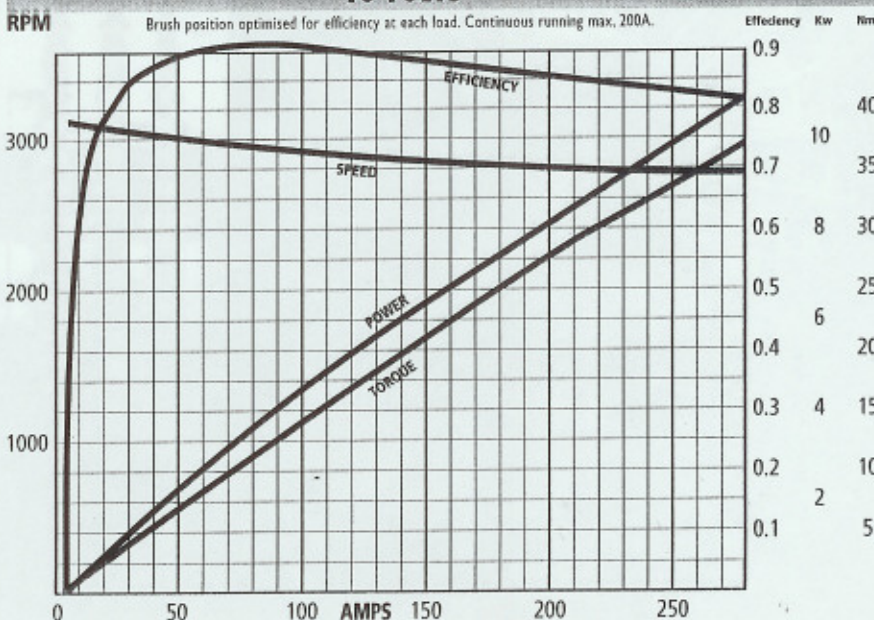

Design of Electric Drives for Boats

Because the power needed to supply the boat drive and auxiliaries – bilge pump, lights, TV &c – must all be carried in the battery, it is important to achieve the highest efficiency possible in converting electrical power from the battery into mechanical power used in overcoming resistance to the boat's motion through the water – ie drag.

Overall efficiency of boats with IC engines can be as low as 15%. Of the 85% of energy wasted, perhaps 1/3 goes in mechanical losses – seals, bearings, gears and gear oil (the latter can absorb several horsepower), and the balance in propeller losses. Because available energy is limited in electric drives, overall efficiencies of more than 50% are aimed at – roughly 80% motor and drive train and 63% propeller. The calculations of range given below are based on this assumption.

Design of the drive system should be taken in the following stages.

1. Hull Drag

It is essential to have a curve, or set of figures, giving the drag of the boat's hull against speed. The figures given by boat designers may be suspect – what equations have they fed into their computers? How often do they measure the drag of the hulls they design?

If in doubt, it is best to measure the drag of the hull to be fitted out by towing it – preferably without propeller – with a spring balance. Readings in lbs or kgs can be taken and then converted into force in Newtons.¹

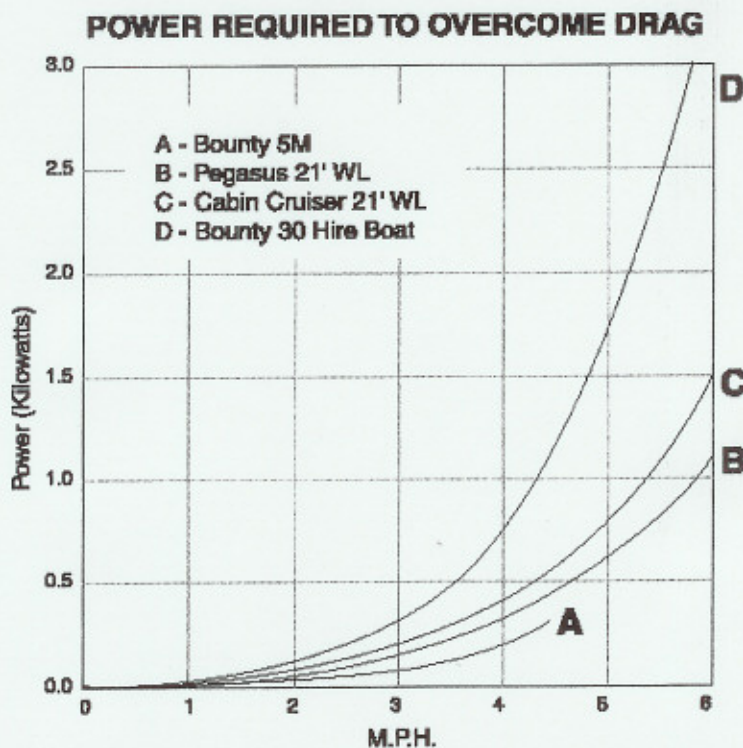

Fig 1 gives power in Watts required to overcome drag – derived from towing – for a typical 4-berth sailing boat and cabin cruiser, both with 21ft waterline length. A remarkable conclusion is that they

¹ To convert kgs to Newtons multiply by 9.81 (acceleration due to gravity); to convert lbs to Newtons multiply by 4.45 (2.2 lbs – 1kg).

need only about 1 Horsepower to drive them at 5mph (1BHP – 746W). Power requirement would rise very rapidly as the so-called hull speed is approached – about 6mph – and could easily be multiplied 4 or 5 times without much increase in speed – the extra power going largely into wave-making which can give the false impression that the boat is going faster!

2. Propeller Efficiency

A typical cabin cruiser with IC engine and 15% overall efficiency would require nearly 7 BHP to drive it at 5mph. This requirement could be increased, say, by three times if the speed is about 6mph, thus explaining why a 20 BHP engine might be fitted. If the speed were limited to 5mph, with overall efficiency of 50% a drive unit of about 2 BHP would be needed. This explains why an electric motor of 1.6 KW would be adequate for the job.

Excessive propeller losses are generally due to using too small a prop – perhaps 12" diameter on a 21ft sail drive or 14" on a 23ft launch. Optimum diameters might be up to 18" and 20" respectively, but compromises may be necessary in light of available draught and hull clearance. At these large diameters, sail drive propellers should be of the folding type, otherwise propeller drag when sailing will be too big. The general design approach is to fit as large a propeller as can be accommodated. Because of the relatively low power transmitted such propellers could be of lightweight construction with blades of plastic or hard rubber if desired, but these are not commercially available at present.

We have seen above that propeller efficiencies of at least 63% are required, though higher values are desirable as they will further put up the range of the boat. To achieve this, propeller slip will generally be below 20% - ie propeller speed (pitch x revs per hr, in MPH – pitch converted to miles!), about 25% greater than boat speed. A good propeller design procedure (or designer if affordable) will suggest optimum characteristics for the largest propeller to fit a given space on a boat with a specified drag curve.

This will determine, say, boat speed against propeller efficiency. If efficiency is less than 63% at the desired cruising speed, then the principal options are either to drop the cruising speed or live with the reduced efficiency and increase the battery pack.

Reducing cruising speed need not be disastrous, as power required varies roughly as the cube of the speed. Thus a reduction of say 1/4mph at 5mph (5%) reduces power needed by about 14%, increasing range by 16%.

Our own experience confirms the importance of propeller diameter as a key factor. For example increasing prop diameter from 18" to 19" on our electric outboards on Lord St Davids' narrow boat increased efficiency by 10%.

3. Range and Battery Size

A typical 6 volt lead-acid battery (e.g., Oldham 3KQ11) has 175 Ampere Hour capacity at 5 hour rate² and 230AH at 20 hour rate and weighs 29.5 Kg. The specific capacity is therefore $6 \times 175/29.5 = 35$ Watt hours per Kg at 5 hr rate and 46.7WH/Kg, 20 hrs.

In practice, batteries should not generally be discharged to more than 80% of their full capacity, so this factor should be included in any calculations of available power.

As an example, taking the above figures, the size of battery pack needed for 20 hrs cruising of an auxiliary drive fitted to the sailing hull whose drag is given in Fig. 1, is worked out as follows. Overall efficiency is assumed to be 50%³.

² i.e. battery is fully discharged over 5 hours.

³ $\text{Weight of battery pack} = \frac{\text{Total Watt Hours required}}{\text{Specific capacity} \times 80\%}$

Speed	Mechanical Power (W)	Electrical Power (W) ⁴	Total WH ⁵	Battery Wt. Kg.	No. of Batteries	Approx. cost £
3.0	140	280	5,600	150	5	500
3.5	220	440	8,800	235	8	800
4.0	320	640	12,800	343	12	1200

If the range of 60-80 miles cruising is greater than required, the battery pack can be scaled down pro-rata. Cruising at higher speeds will reduce the range further. Good performance can be achieved without greatly reducing the range by having means of increasing battery voltage, and hence propeller rpm, in an emergency only – e.g. for braking or manoeuvring, or adverse currents.

It should not be necessary to increase rpm to cope with increased wind drag with a large diameter propeller as this should have sufficient “grip” and will thus take more power from the motor to overcome excess resistance without a big reduction of boat speed.

4. Mechanical Losses

These should be measured separately as far as possible and reduced to a minimum. Gear boxes should be avoided as far as possible as with normal oil they can easily absorb 500-600 Watts. If essential they should, if possible, be filled with the minimum of the lightest oil allowed with an additive such as Molybdenum Disulphide.

Deep Sea seals, properly adjusted, absorb only a few Watts – they are preferable to stuffing boxes. Cutless bearings also generally have low losses provided they are carefully aligned and adequately lubricated.

Summary

Essential steps in planning an electric drive are

1. Obtain hull drag
2. Minimise and estimate mechanical losses
3. Maximise and estimate propeller efficiency
4. Decide on cruising speed and calculate power required
5. Decide on range, choose battery type and calculate size of battery pack.

⁴ Twice mechanical power at 50% efficiency.

⁵ Electrical power x 20 – Watt Hours.

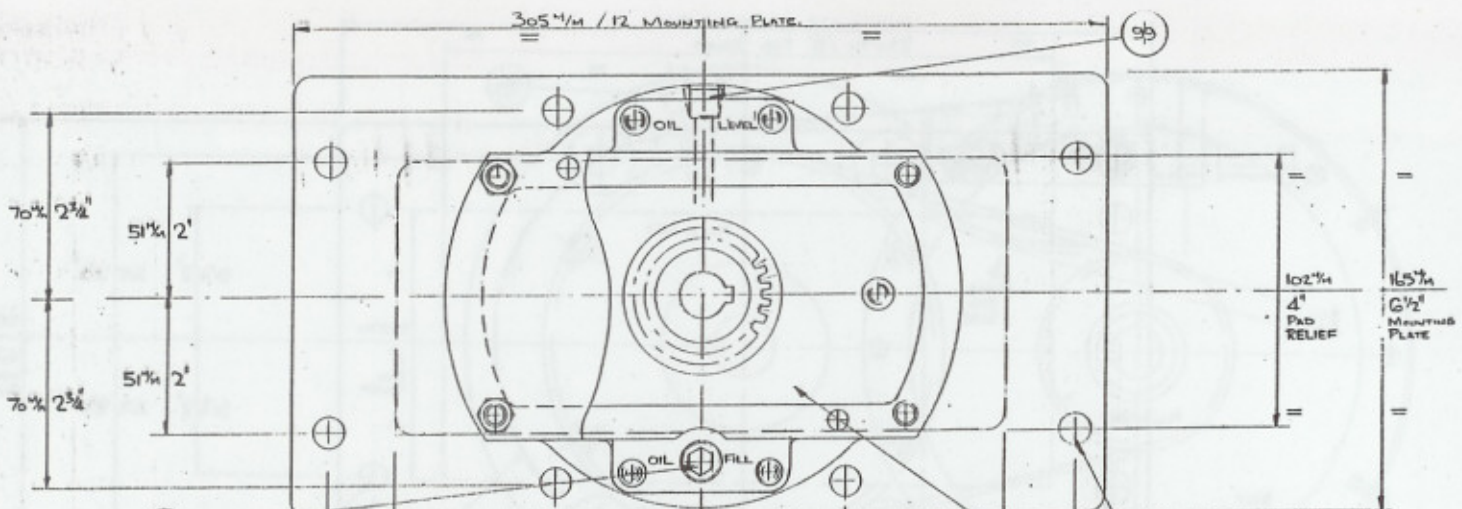

2 MOUNTING HOLES USE M10 OR #3/16 BOLTS or STUDS

PLAN VIEW WITH MOTOR REMOVED & MOTOR FLATE #932 CUT AWAY.

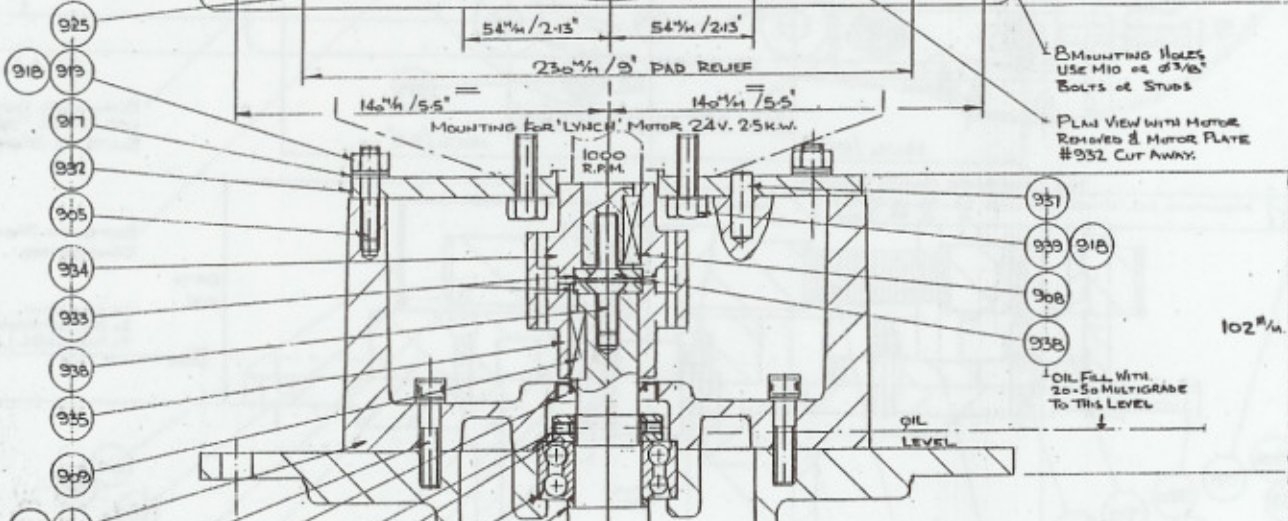

OIL FILL WITH 20-50 MULTIGRADE TO THIS LEVEL

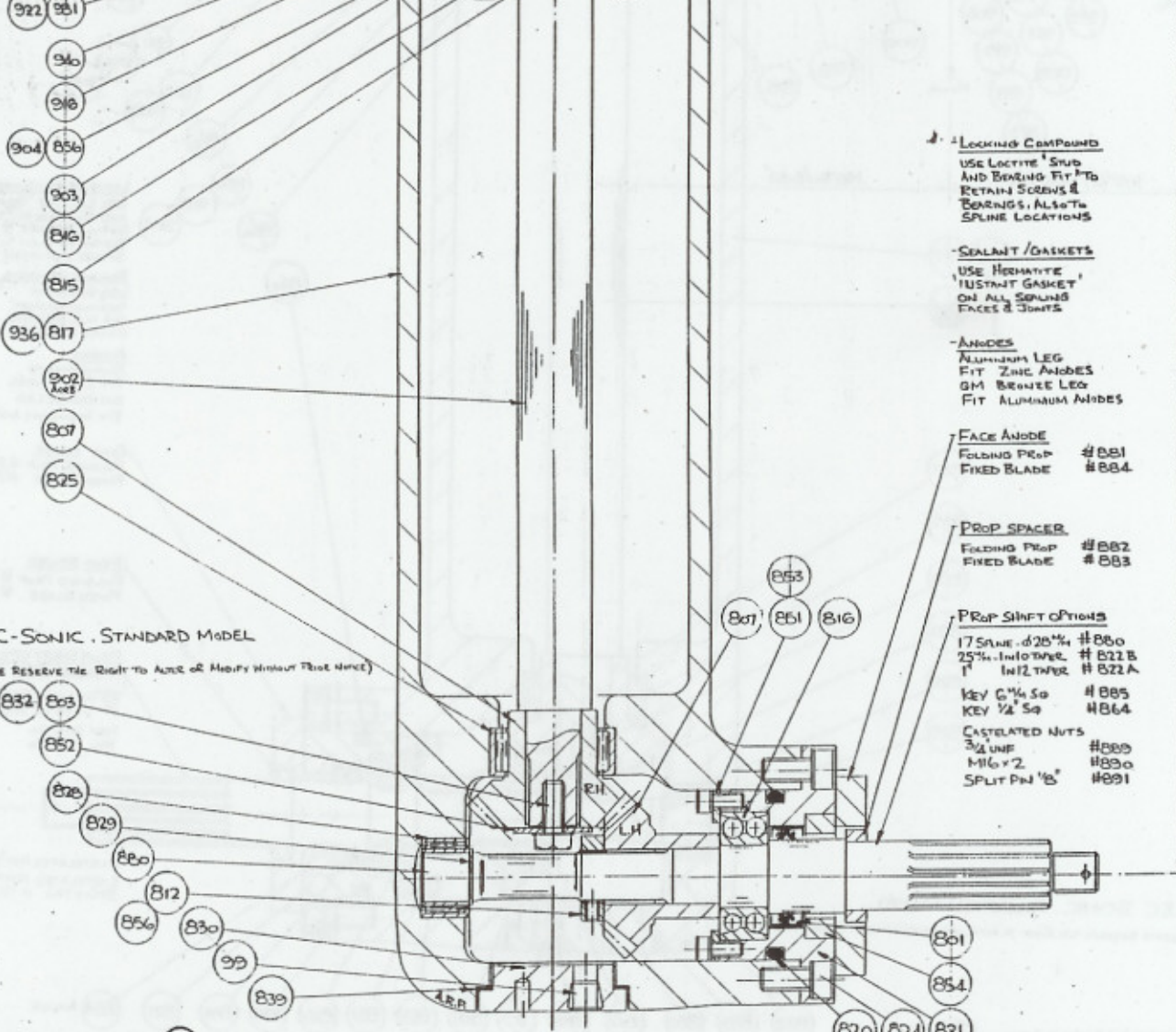

LOCKING COMPOUND
USE LOCTITE 1 STUD AND BRASSING FIT TO RETAIN SCREWS & BOLDS. ALSO TO SPLINE LOCATIONS

SEALANT / GASKETS
USE HERMATITE INSTANT GASKET ON ALL SEALING FACES & JOINTS

ANODES
ALUMINUM LEG FIT ZINC ANODES
GM BRONZE LEG FIT ALUMINUM ANODES

FACE ANODE
FOLDING PROP #881
FIXED BLADE #884

PROP SPACER
FOLDING PROP #882
FIXED BLADE #883

PROP SHAFT OPTIONS
17 Spline - 0.25" #880
25 Spline - 0.25" #822 B
1" IN 12 TAPER #822 A
KEY 6/16" SQ #885
KEY 1/2" SQ #884
CASTELATED NUTS 3/4 UNF #889
M16 x 2 #890
SPLIT PIN 1/8" #891

STD 380MM 15"
OPTION 230MM 9"
STD MATERIAL ALUMINUM
OPTION G.M. BRONZE.

ELEC-SONIC . STANDARD MODEL
(SILLETTE RESERVE THE RIGHT TO ALTER OR MODIFY WITHOUT PRIOR NOTICE)

Champion® Deep Cycle Battery Specifications

BATTERY PART NUMBER	Battery DC Volts	Capacity						Nominal Battery Dimensions (Inches/mm)			Nominal Weight ² (lbs./kg)
		20 Hour Rate		8 Hour Rate		3 Hour Rate		X LGTH	Y WDT	Z HT'	
		AMP-HRS	KWH	AMP-HRS	KWH	AMP-HRS	KWH				
MB3CHP12V24	12	92	1.10	80	0.94	70	.82	10.25 260	6.85 174	8.80 224	55 25
MB3CHP12V27	12	110	1.30	95	1.10	85	1.00	12.05 306	6.85 174	8.80 224	65 29.5
MB3CHP06V27	6	220	1.30	195	1.15	175	1.03	12.05 306	6.85 174	8.80 224	67 30.5

¹ Height to top of post. Bolt, washer and connector typically increases height by 0.450 in. (11mm)

² Weight +/- 1 kg +/- 2.2 lbs

Champion® Deep Cycle Battery Design

- Absorbed Glass Mat Separator** - Retains electrolyte in highly porous mat to prevent leakage and promote efficient recombination of charging gases.
NO WATERING REQUIRED.
- Proprietary MFX Grid Alloy in Positive Plate** - Deeper discharges and reduced gassing during recharge.
LONGER RUN TIMES & BATTERY LIFE.
- M6 Bolts, Brass Inserts and Bolt-On Connectors** - Reduced electrical resistance and increased voltage.
IMPROVED RUN TIME & LONGER LIFE FOR TRUCK'S ELECTRICAL COMPONENTS.
- Self-Sealing Pressure Relief Valve & Flash Arrestor** - Internal pressure controlled for efficient recombination during recharge. (Safety vent opening pressure of 1-4 psi) Anti-flame design prevents sparks from entering cell.
LONGER BATTERY LIFE & SAFER OPERATION.
- Reinforced Polypropylene Container & Cover**
- Lead Calcium Alloy Negative Plate**

NOTE:

Packaged complete with SS-316 bolts and washers.

Weekly Self-Discharge 0.5 - 1.0%

Design or specifications subject to change without notice.

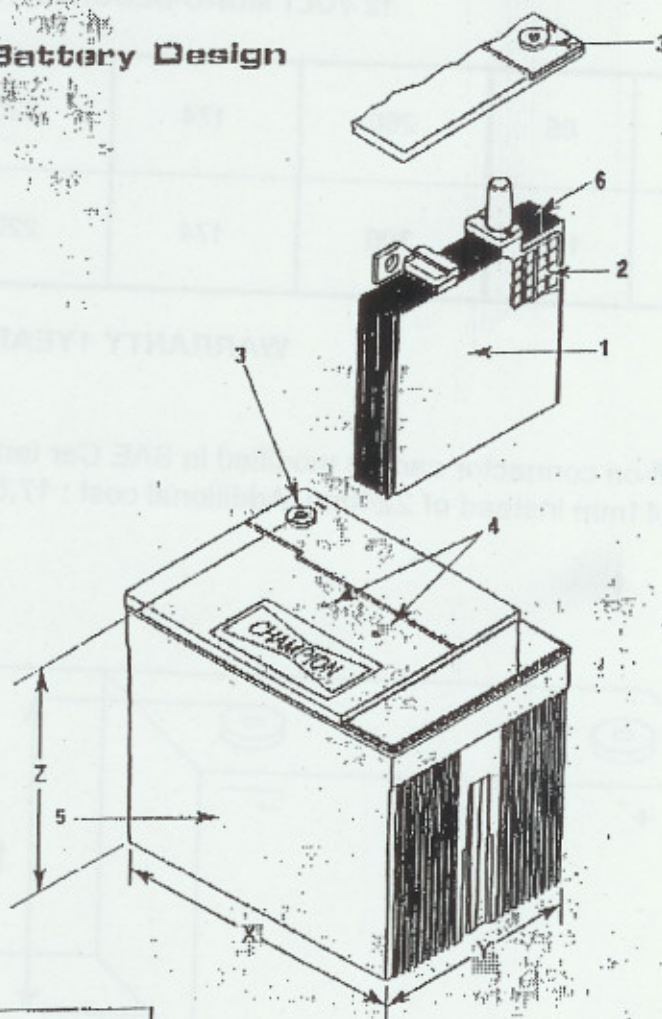

Terminal Position

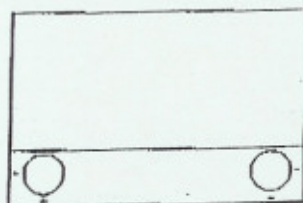

12-Volt Unit

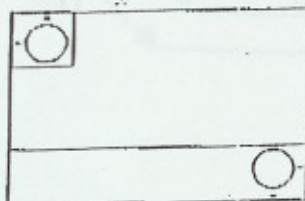

6-Volt Unit

"CHAMPION" MONOBLOC

VALID FROM : January, 15th 2001

Type Cells	C/5 Ah (at 30°C)	Length mm a	Width mm b	Height mm		Weight Kg
				h	H	

6 VOLT MONO-BLOCK BATTERY

M 83 CHP 6V27	200	306	174	220	224	28
---------------	-----	-----	-----	-----	-----	----

12 VOLT MONO-BLOCK BATTERY

M 83 CHP 12V24	85	260	174	220	224	24
M83 CHP 12V27	100	306	174	220	224	28

WARRANTY 1YEAR

Option : the M6 Bolt-on connector can be modified in SAE Car terminal connector. In this case the H dimension will be 241mm instead of 224mm. Additional cost : 17,5 EURO by block.

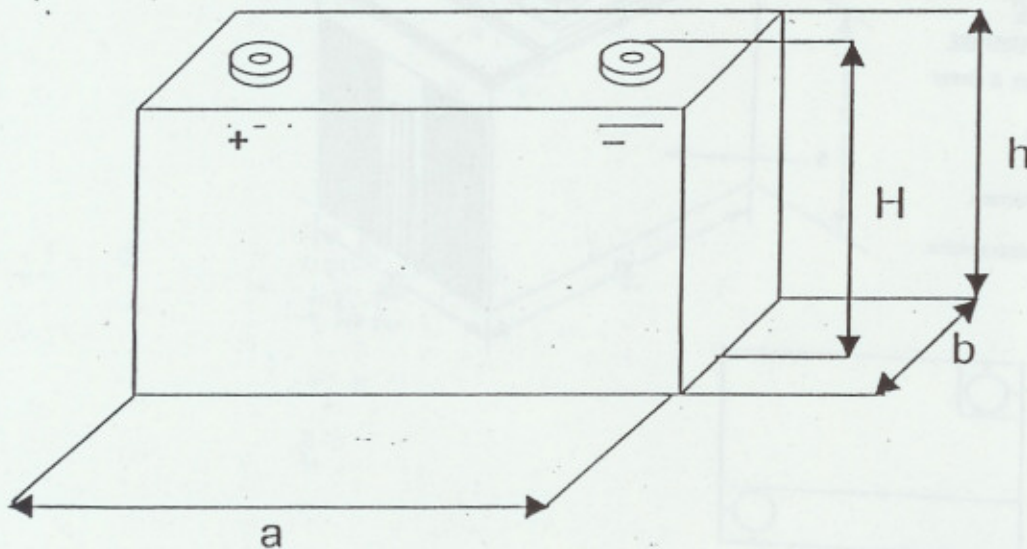

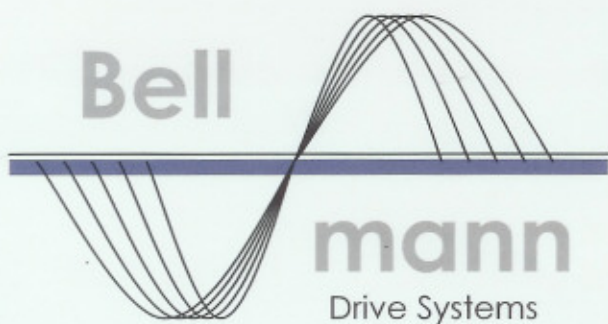

Sillette-Sonic Ltd

Unit 2, Beverley Trading Estate, 190-192 Garth Rd,
Morden, Surrey, SM4 4LU, UK
email: sales@sillette.co.uk
website: www.sillette.co.uk
Tel: 020 8337 7543
Fax: 020 8330 9014

**Aquapella
Saildrive
10000 & 15000**

High power electric sail drives



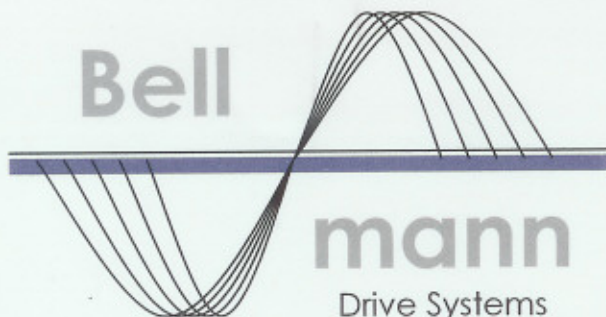

Aquapella Saildrive 10000 & 15000

- No maintenance
- Synchronous motor
- Very high efficiency
- Water cooled
- Easy and quick installation
- 10 and 15 kW units
- Complete system

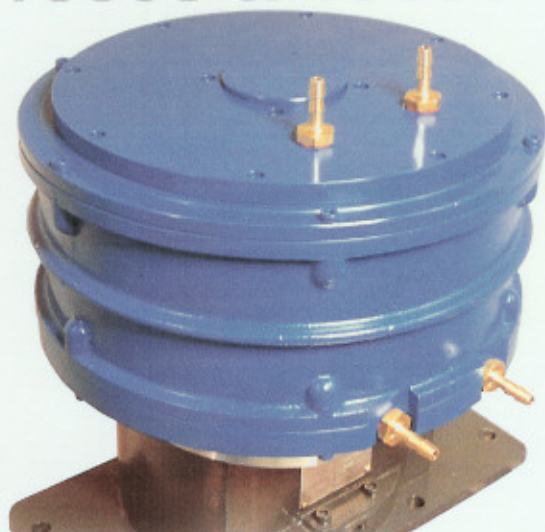

The Aquapella sail drive system is developed for larger displacement vessels for which a stern tube drive is not an option. The sail drive leg is quite thin and shaped in such a way that water can easily flow to the propeller. The water cooled synchronous motor has an efficiency of 91%. A modern sensorless speed controller converts the battery voltage into a three phase voltage of variable amplitude and frequency.



Technical data Aquapella Saildrive 10000

Power	10 kW at the shaft
Propeller speed	1400 RPM
Voltage	144 VDC (nominal)
Efficiency	appr. 87 % for the complete system

Technical data Aquapella Saildrive 15000

Power	15 kW at the shaft
Propeller speed	1400 RPM
Voltage	144 VDC (nominal)
Efficiency	appr. 87 % for the complete system



Aquapella Saildrive 10000 & 15000

Manufactured by:

Bellmann B.V.

Witte Paal 104

1742 NW Schagen

The Netherlands

Tel. +31 (0) 224-217180

Fax. +31 (0) 224-217190

www.bellmann.nl

info@bellmann.nl

Electric Marine Propulsion System

Marine Control and Shunt Assembly

We offer a range of power and voltages specifically for the Sillette-Sonic Saildrive leg these have been developed over many years of stringent tests to ensure the correct components offer the most efficient system.

Motors

Ranging from 24v 2.8kw to 48v 8Kw speed will depend on the working voltage.

Control Assemblies

The electronics are selected to the relevant working voltage these are custom built to your specifications and are supplied complete with installation instructions and necessary drawings.

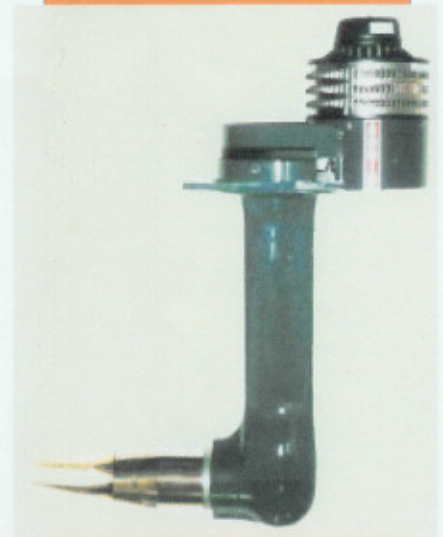

Authorized Dealer & Saildrive Manufacturer

Sillette-Sonic Ltd
Unit 2 Beverley Trading Estate
190/192 garth Road
Morden
Surrey
SM4 4LU
Tel: +44 (0) 20 8337 7543
Fax: +44 (0) 20 8330 9014
Email: sales@sillette.co.uk
Web: www.sillette.co.uk

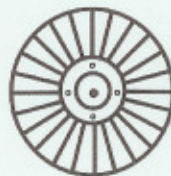

L.M.C.
THE LYNCH MOTOR COMPANY

Marine Display Panel & Throttle

The display panel includes the battery monitor and a lockable keyswitch with waterproof cover.

The battery monitor acts in the same way as a fuel gauge, this is capable of displaying voltage, current, consumed ampmours, remaining battery capacity and time remaining.

This is supplied fitted to the panel along with wiring details for ease of installation.

Traditional marine throttle right hand version shown however we can offer left or right hand please specify at time of ordering.



Lynch Motor Company Ltd
Unit 8 Park Court
Heathpark Industrial Estate
Honiton
Devon
Ex14 1SW
England
Tel: +44 (0) 1404 549940
Fax: +44 (0) 1404549546
Email: sales@lmcltd.net
Web www.lmcltd.net

 **L.M.C.**
THE LYNCH MOTOR COMPANY

Sillette-Sonic Ltd

Sales & Correspondence to:
Unit 2 Beverley Trading Estate
190/192 Garth Road, Morden
Surrey SM4 4LU - UK

tel: +44 (0)20 8337 7543
fax: +44 (0)20 8330 9014
e-mail: sales@sillette.co.uk
website: www.sillette.co.uk

ELECT SONIC SAILDRIVE AND ACCESSORIES PRICE LIST

RETAIL

DRIVE UNITS

MKII Elect - Sonic Saildrive, Direct Drive Model, Aluminium (Bronze £300 extra)			£1,800
MKII Elect - Sonic Saildrive, 2:1 Reduction Model, Aluminium (Bronze £300 extra)			£2,000
3/4 / 1 ton - Hydrodrive 2:1 Reduction Aluminium (Bronze £550 extra)			£2,300
MKI Elect - Sonic Lower Unit for use with up to 30 kw/22kg mtr (Bronze £630 extra)			£2,200

PROPELLERS

Fixed 2 Blade Aluminium Propeller & Nose Cone Kit	Ø 15" £240	Ø 16" £245	Ø 17" £260
Fixed 3 Blade Aluminium Propeller & Nose Cone Kit	Ø 14" £275	Ø 15" £285	Ø 16" £290
Fixed 2 Blade Bronze Propeller Taper Fitting, K11	Ø 15" £230	Ø 16" £265	Ø 17" £285
Fixed 3 Blade Bronze Propeller Taper Fitting, E13	Ø 14" £255	Ø 15" £260	Ø 16" £300
Folding 2 Blade Gori Sail Drive Propeller	Ø 14" £800	Ø 15" £810	Ø 16 1/2" £820

MOTOR & ELECTRICS FOR 24V DIRECT DRIVE MODEL - LYNCH SYSTEM

LEM 200. D135 motor for mounting to Sonic direct drive saildrive.

Max output 2.8 kw - 1000 rpm: ZF top mounted, RH single level control, ahead/astern/ speed control (LH to order). Includes shunt and fuses in an ABS case, and controller/heat sink both internally wired. Connecting wire supplied in lengths with plug terminations for self assembly to detailed instruction. Together with keyswitch, battery display mounted on a green panel
(Main power cables from battery to isolator/shunt box/motor not supplied)

£2,750

MOTOR & ELECTRICS FOR 36V REDUCTION MODEL - LYNCH SYSTEM

As above for connection to Sonic or Hydrodrive 2:1 reduction

Max output 4.5 kw - 1500rpm

£2,850

MOTOR & ELECTRICS FOR 48V REDUCTION MODEL - LYNCH SYSTEM

As above for connection to Sonic or Hydrodrive 2:1 reduction.

Max output 8kw - 2000rpm

£3,000

MOTOR & ELECTRICS FOR 24V DIRECT DRIVE MODEL - BELLMAN SYSTEM

Motor PMG 132 Max output 2.4 kw - 1120 rpm includes. Controller with fan cooling, joystick and display, mains switch 250A, fuseholder and fuse, cable set and module charger (main power cables not supplied)

£3,300

MOTOR & ELECTRICS FOR 36V & 48V FOR 2:1 REDUCTION SONIC SAILDRIVE - BELLMAN SYSTEM

As above rated at 3.6 kw - 1680 rpm and 4.8 kw - 2240 rpm respectively

£3,600

BATTERY & CHARGER OPTIONS 24V

2 x 100 A.h - 12 V Monobloc deep cycle batteries
(2-4 hrs cruising approx. - weight abt 60 kilos)

£500

4 X 100 A/h - 12V Monobloc deep cycle batteries
(3-6 hrs cruising approx. - weight abt 120 kilos)

£900

24V - 16 amp - Zivan Battery charger (confirm battery type when ordering)

£330

BATTERY CHARGER OPTIONS 36V

3 x 100 A/h - 12V Monobloc deep cycle batteries
(2-4 hrs cruising, approx. - weight abt 90 kilos)

£700

6 x 100 A/h - 12V Monobloc deep cycle batteries
(3-6 hrs cruising approx. - weight abt 180 kilos)

£1,400

36V - 24 amp - Zivan Battery charger (confirm battery type when ordering)

£550

GENERAL

Battery cables 19mm - specify red or black - per metre

£25

For further options on batteries, chargers and a range of electrical fittings contact:- Merlin Equipment tel: 01202-697979/www.power-store.com

Also for batteries contact Odyssey tel:- 0161 794 4611 odysseybattery.com & odysseysales@uk.energys.com

NOTE

Electrical components are not manufactured by Sillette and are therefore subject to specification and price changes beyond our control, please check when ordering.

Detail on Bellman system from Sillette or call Bellman B.V. on 0031 224 217180 for technical info.

- www.bellmann.nl

Detail on Lynch System from Sillette or call LMC Ltd 01404 549940 for technical info.

- www.lmcltd.net

Due to continual development and other factors Sillette-Sonic Ltd reserve their right to alter, modify or replace any specification or design feature without prior notice, please check when ordering.

CARRIAGE & PACKING EXTRA
PRICES SUBJECT TO FLUCTUATION

JAN 2010

All prices listed are subject to UK VAT.