

SONIC LIGHTWEIGHT STERN DRIVES 70

HAND OR HYDRAULIC TILT

DIRECT DRIVE

FOR USE WITH:

- Petrol Engines 20 to 60HP
- Diesel Engines 9 to 50HP
- Electric Motors 4 to 25KW

REDUCTION RATIOS:

1 : 1 STANDARD

1.25 : 1 OPTIONAL

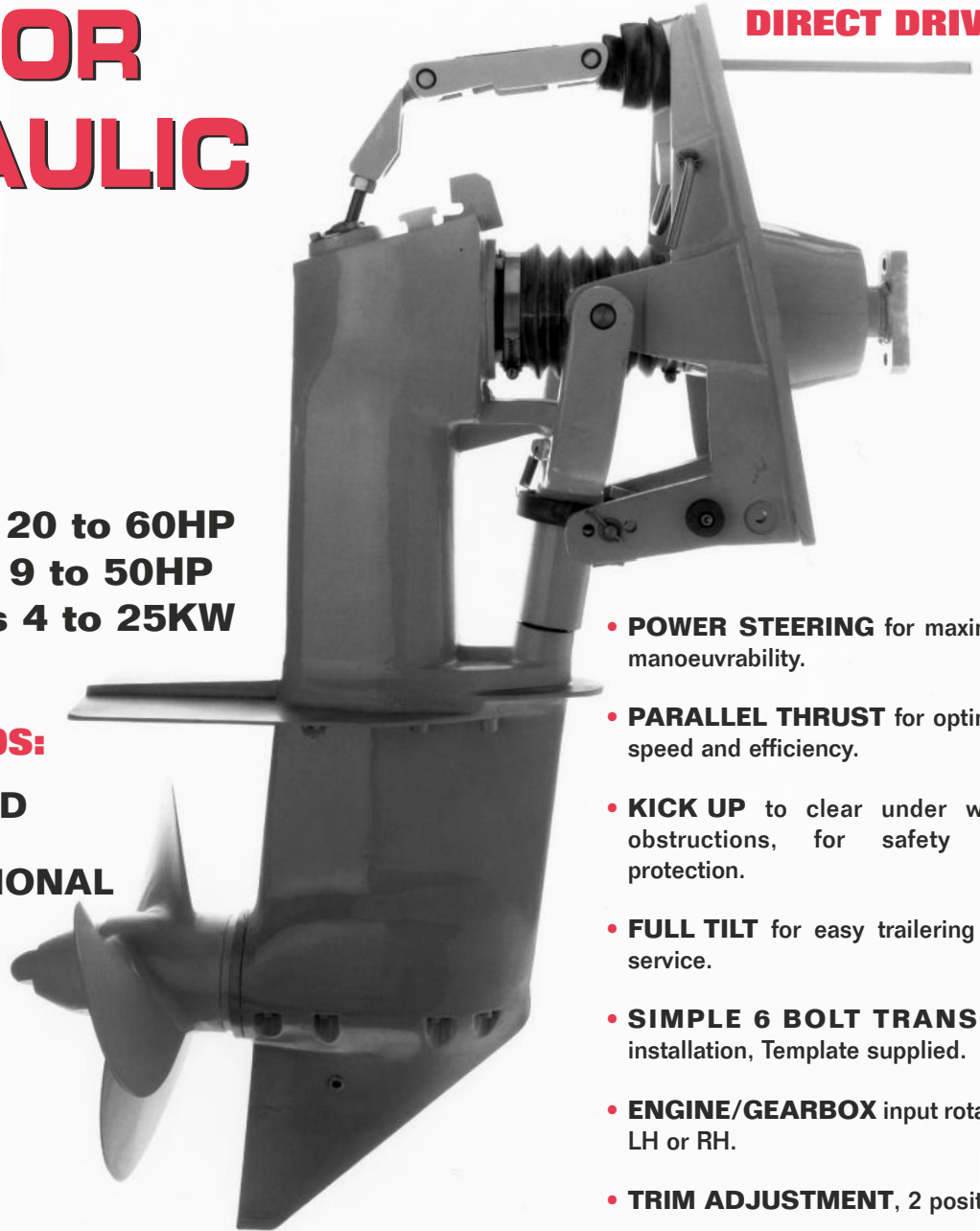

- **POWER STEERING** for maximum manoeuvrability.
- **PARALLEL THRUST** for optimum speed and efficiency.
- **KICK UP** to clear under water obstructions, for safety and protection.
- **FULL TILT** for easy trailering and service.
- **SIMPLE 6 BOLT TRANSOM** installation, Template supplied.
- **ENGINE/GEARBOX** input rotation LH or RH.
- **TRIM ADJUSTMENT**, 2 position.
- **STREAMLINE** underwater section.
- **MARINE GRADE** alloy casing.
- **NICKEL ALLOY GEARS.**
- **STAINLESS STEEL FASTENERS.**
- **DOUBLE OIL SEALS** (Prop shaft).
- **SACRIFICIAL ANODE** provision.

SONIC TRANSMISSION UNITS ARE DESIGNED WITH SERVICE IN MIND. THE RUGGED BUT REFINED CONSTRUCTION ENABLES COMPLETE OVERHAULS TO BE CARRIED OUT WITH MINIMUM TOOLS. A FACILITY NOT ALWAYS POSSIBLE WITH OTHER TYPES OF MASS PRODUCED DRIVES.

Due to continual development Sillette - Sonic Limited reserve the right to alter, modify or replace any specification or design feature without prior notice.

HYDRAULIC PUMPS & PISTON SETS

for SONIC/Enfield Stern Drives and Cat-Drives



Standard hydraulic piston, pump and hose are suitable for fitting to all the Sonic Stern Drive Range, in addition they are available for many other applications.

Hand Hydraulic Pump, raises unit with 12 pumps of the lever
or
12V Electro Hydraulic Pump with switch control. Both use common lift cylinder, 1" Diameter - 3" Stroke.

TECHNICAL DETAILS

Engine and Gearbox combinations must be within HP - RPM and torque specifications for Sonic 70 and approved by Sillette Sonic Limited in writing prior to purchase.

Ratios 1:1 Standard. 1.25:1 Special Order. Direct Drive.

Linked or manual safety latch allows Kick-Up in Forward, but locks down in reverse • Capable of LH or RH output rotation • All Steel Tiller Arm • Double sealed Prop Shaft • Maximum Prop Diameter 15" • Accepts Transom Angles 7° and 12° • Anodes fitted • Approximate dry weight 84lbs (38kg) • Easy Fitting • Full Instructions.

Max. Power

60hp C.V. PS. PK. @ 5000 rpm/upm. SAE. PETROL, Subject to torque limitation - 45kw
50hp C.V. PS. PK. @ 3600 rpm/upm. SAE. DIESEL, Subject to torque limitation - 37kw

Max. Input Torque : 20kg/Mtr – 145lbs/ft
i.e. Max input torque = Engine torque x overall ratio (reduced by 10% for commercial use)

Reduction Ratios

1 - 1 : Standard • 1.25 : 1 Special • Direct Drive.

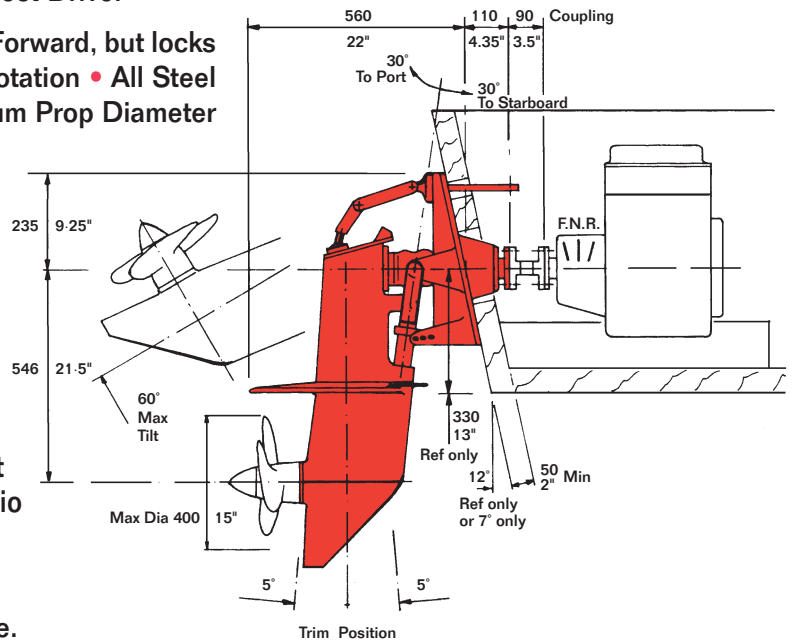

ENGINE ADAPTORS AND FLEXIBLE COUPLINGS

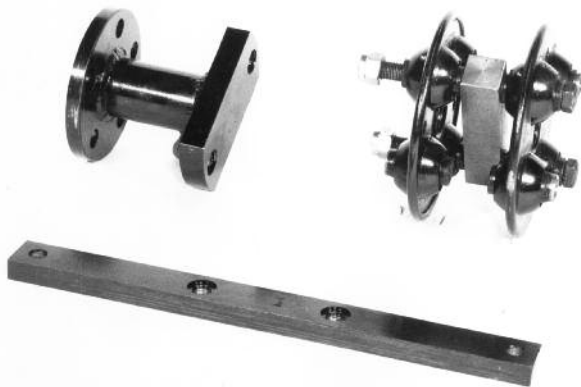

ENGINE RANGE

Yanmar	1GM10, 2GM20, 3GM30, 3JH3	: 9 to 40hp
Lombardini	LDW502, LDW702, LDW1003, LDW1404, LDW1503	: 13 to 39hp
Beta	TEN, BZ482, BD722, BD1005, BV1305, BV1505	: 13 to 37hp
Nanni	245ECO, 250HE, 3.75HE, 3.100HE, 4.150HE, 4.195HE	: 10 to 40hp
Volvo	2010, 2020, 2030, 2040, 2001, 2002, 2003	: 10 to 38hp
Perkins	M20, M30 – Leyland 1.5	: 20 to 30hp
Electric Motors	Lynch, etc... 24v, 36v, 48v	: 3 to 20kw

Adaption available for listed engine and gearbox combinations
Marine Engines available from Sillette • For other possibilities check with Sillette.

An Extensive Range of Propellers • Couplings Adaptors • Spare Parts
• Morse Teleflex Controls • Marinizing & Fitting Out Equipment available • Worldwide Mail Order Service.

Also Available:

Sonic Sail Drives – 2 Models • Sonic Catamaran Drives – 4 Models
Reduction Gearboxes • Onboard Service Kits/Tools